

DINOX, we process your dream



# SMH <sup>NEW</sup> BORING SET

Precise Adjustment tool - SMH (Ø0.002)



 **DINE Inc.**



# SMH Boring Set

## 1. Features

- SMH Head ( $\text{Ø}0.002$ ) for precise scale adjustment
- Modular type micro boring for small diameter
- Range
  - ▶ SMH(SET1)/(SET2)/(SET4) :  $\text{Ø}6.0 \sim \text{Ø}44.0\text{mm}$
  - ▶ SMHW(SET3) :  $\text{Ø}1.0 \sim \text{Ø}34.0\text{mm}$  (with Jig Boring Bite & Sleeve)
- Adjustment Range : 7mm
- 2 Types of Bite : BB Bite (standard) and Carbide Bite

## 2. Precise Adjustment tool - SMH ( $\text{Ø}0.002$ )

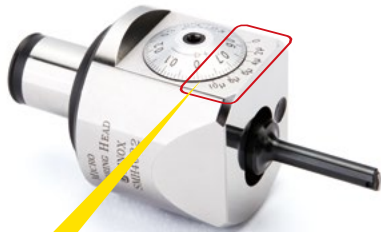

- ✓ Setting by  $2\mu\text{m}$
- ✓ More accurate size setting by using small scale from sub-scale

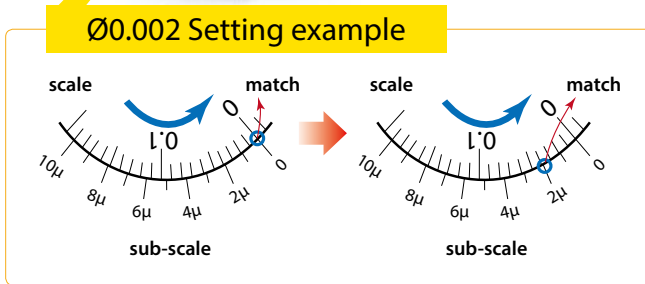

- ▶ At the Setting size, check if main and sub-scale meet each other at '0' exactly.
- ▶ Turn the main-scale counter-clockwise, then find the first meeting point with main-scale and 'numerical' sub-scale (like 2, 4 ..10)  $\mu\text{m}$ .
- ▶ Same Usage with Vernier Calipers

## 3. Set Composition

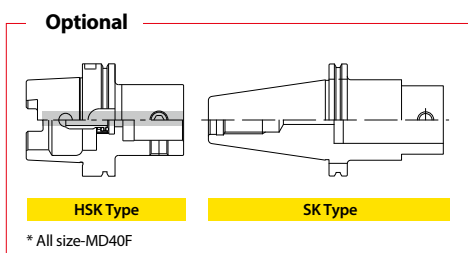
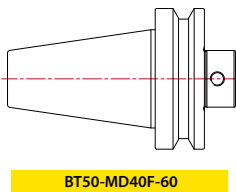
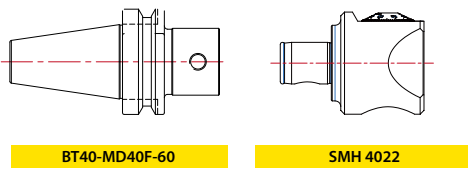

		Boring Depth
Steel Bite	BB16-3090(S)	89mm
	BB16-2590(S)	80mm
	BB16-2083(S)	70mm
	BB16-1668(S)	56mm
	BB16-1253(S)	42mm
	BB16-1040(S)	35mm
	BB16-0832(S)	28mm
	BB16-0624(S)	20mm
	CB16-195-175	130mm
	Carbide Bite	SMH-CS12
SMH-CS8		70mm
CB12-145-140		10mm
CB8-95-115		2mm
JB8-45		40mm
JB8-15		2mm
SMH-CS6		40mm
CB6-55-95		40mm



## 4. Parts

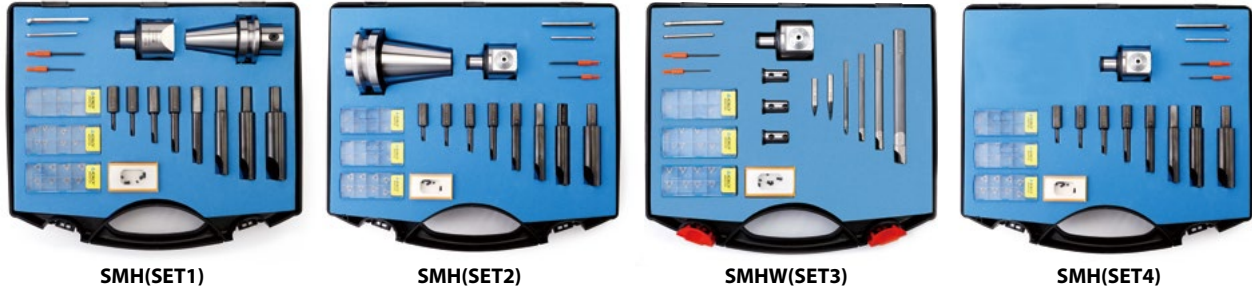

Type	Designation	SMH(SET1)	SMH(SET2)	SMHW(SET3)	SMH(SET4)	Available Inserts
SMH Head	SMH4022	1	1	1	1	
Basic Shank	BT40-MD40F-60	1	-	Optional	Optional	
	BT50-MD40F-60	-	1			
BB Bite	BB16-0624(S)	1	1	-	1	WBG020102L
	BB16-0832(S)	1	1	-	1	WBG020102L
	BB16-1040(S)	1	1	-	1	TPGT080202L
	BB16-1253(S)	1	1	-	1	TPGT080202L
	BB16-1668(S)	1	1	-	1	TPGT110304L
	BB16-2083(S)	1	1	-	1	TPGT110304L
	BB16-2590(S)	1	1	-	1	TPGT110304L
Carbide Bite	BB16-3090(S)	1	1	-	1	TPGT110304L
	JB8-1S	-	-	1	-	
	JB8-4S	-	-	1	-	
	CB6-5S-9S	-	-	1	-	WBG020102L
	CB8-9S-11S	-	-	1	-	TPGT080202L
	CB12-14S-140	-	-	1	-	TPGT110304L
Sleeve	CB16-19S-175	-	-	1	-	TPGT110304L
	SMH-CS06	-	-	1	-	
	SMH-CS08	-	-	1	-	
Clamping Screw (Spares)	SMH-CS12	-	-	1	-	
	BFTX0203A	2	2	2	2	
	BFTX0204A	2	2	2	2	
Spare Parts	BFTX0307A	2	2	2	2	
	LW-3	1	1	1	1	
	LW-5	1	1	1	1	
	TW06 (WBG02, TPGT08)	1	1	1	1	
	TW10(TPGT11)	1	1	1	1	

※ Remark : Insert is NOT included  
 HSK, SK & CAT Basic Shanks are in stock

## 5. Inserts

Maker	KORLOY					
	Cermet	Coated Cermet	PVD Coated		Carbide	CVD coated
Work Piece	Steel		Hardened Steel	Stainless Steel	Cast Iron	Cast Iron
Grade	CN2000	CC115	PC8110	PC9030	G10	NC6210
WBG020102L	●			●		●
TPGT080202L	●	●		●	●	●
TPGT110304L	●	●	●	●	●	●

# Expanded Boring Solution

## Multi purpose boring

**BCH**



**SMH Head  
(Special)**

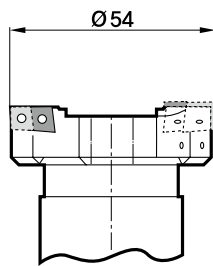

<BCH-35S>

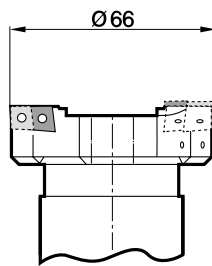

<BCH-46S>

- Ø6~Ø66mm
- For Roughing & Finishing
- 2µm scale

## For wide Boring

**KMB**

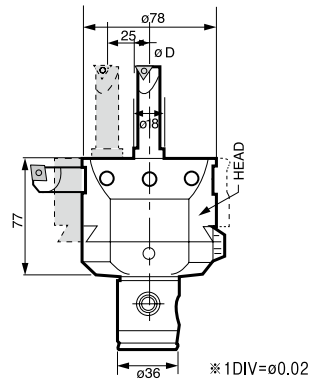

- Ø8~Ø165mm
- Up to 165mm by Side Hole
- 3 Bite positions
- 20µm scale

**DINE Inc.**



### Head Office & 1st Factory

67, 185 Beon-gil, Gunjachun-ro, Shihung-City, Kyungki-Do, Korea (429-849)  
 (Export) TEL. +82-31-488-6203 FAX. +82-31-433-0062

HOME PAGE. <http://www.dine.co.kr> | [www.dinox.co.kr](http://www.dinox.co.kr) e-mail. [dine@dine.co.kr](mailto:dine@dine.co.kr)